

EVAPCO, INC.



UNIT	COOLING TOWER	MODEL #	AT 112-314	SCALE	NTS	DWG. #		REV.		DATE		SERIAL #	
-------------	----------------------	----------------	------------	--------------	-----	---------------	--	-------------	--	-------------	--	-----------------	--

NOTES:

1. (M) - FAN MOTOR LOCATION
2. HEAVIEST SECTION IS UPPER SECTION
3. MPT DENOTES MALE PIPE THREAD
FPT DENOTES FEMALE PIPE THREAD
BFW DENOTES BEVELED FOR WELDING
4. + UNIT WEIGHT DOES NOT INCLUDE ACCESSORIES (SEE SEPARATE DRAWINGS FOR ACCESSORIES)
5. 19mm DIA. MOUNTING HOLES. REFER TO RECOMMENDED STEEL SUPPORT DRAWING
6. MAKE-UP WATER PRESSURE-137 kPa MIN, 344 kPa MAX

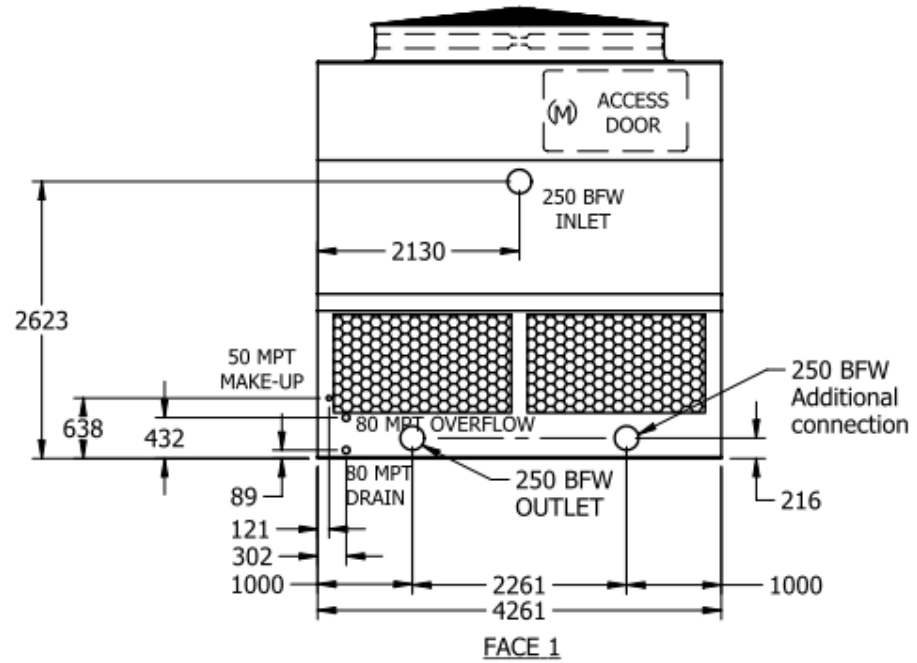
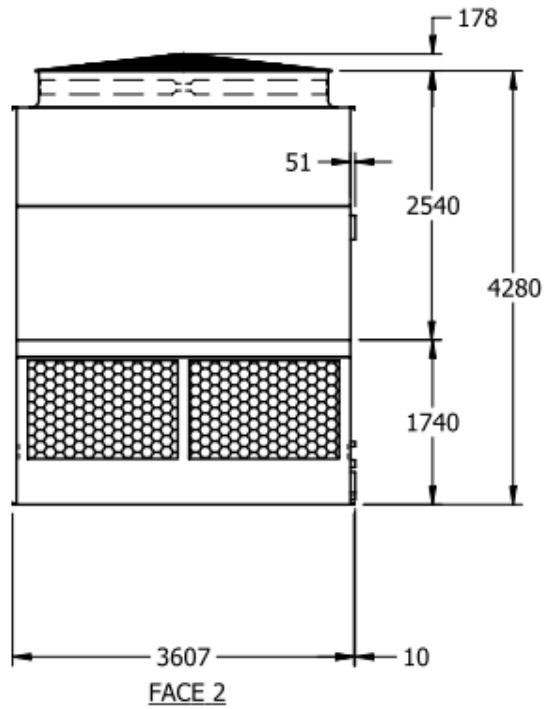
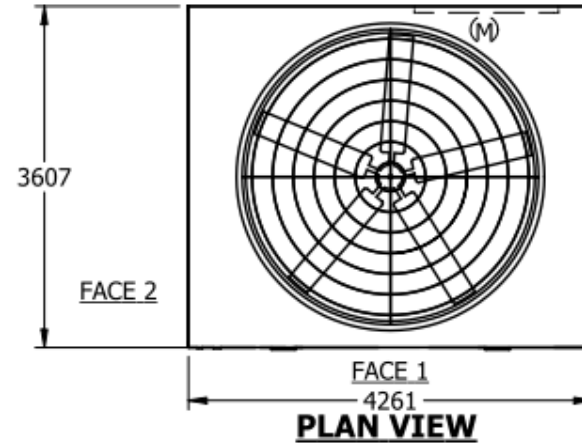

SHIPPING WEIGHT	3750	kg +	OPERATING WEIGHT	7075	kg	HEAVIEST SECTION WEIGHT	2550	kg	NO. OF SHIPPING SECTIONS	2
------------------------	------	-------------	-------------------------	------	-----------	--------------------------------	------	-----------	---------------------------------	---